

BT301 BATTERY TESTER WITH PRINTER

BT501 BATTERY/CHARGING/STARTING SYSTEM ANALYZER / PRINTER

TEST PROCEDURES / OPERATING INSTRUCTIONS

IMPORTANT :

1. For testing 6 and 12 volt batteries (BT301/BT501), and for testing 12 and 24 volt charging systems (BT501).
2. Suggested operation range 0°C(32°F) to 50°C(122°F) in ambient temperature.

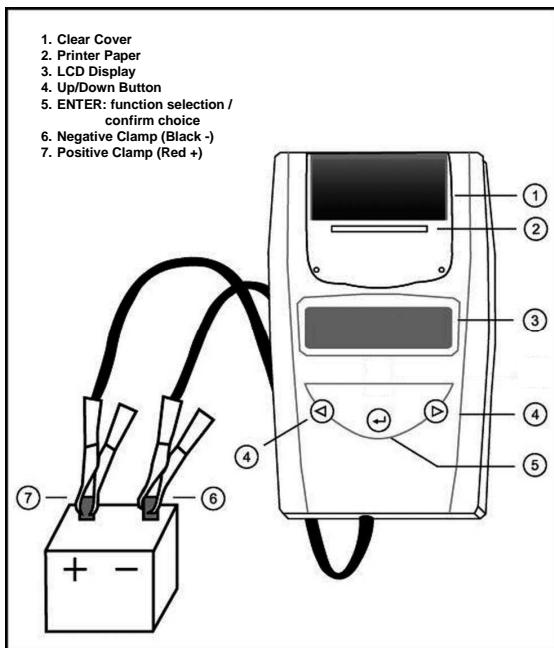

WARNING :

- 1.** Working in the vicinity of a lead acid battery is dangerous. Batteries generate explosive gases during normal battery operation. For this reason, it is of utmost importance, if you have any doubt, that each time before using your tester, please read these instructions very carefully.
- 2.** To reduce risk of battery explosion, follow these instructions and those published by the battery manufacturer and manufacturer of any equipment you intend to use in the vicinity of the battery. Observe cautionary markings on these items.
- 3.** Do not expose the tester to rain or snow.

PERSONAL SAFETY PRECAUTIONS :

- 1.** Someone should be within range of your voice or close enough to come to your aid when you work near a lead acid battery.
- 2.** Have plenty of fresh water and soap nearby in case battery acid contacts skin, clothing or eyes.
- 3.** Wear safety glasses and protective clothing.
- 4.** If battery acid contacts skin or clothing, wash immediately with soap and water. If acid enters eye, immediately flood eye with running cold water for at least ten minutes and get medical attention immediately.
- 5.** NEVER smoke or allow a spark or flame in vicinity of battery or engine.
- 6.** Be extra cautious to reduce risk of dropping a metal tool onto the battery. It could spark or short-circuit the battery or other electrical parts and could cause an explosion.
- 7.** Remove personal metal items such as rings, bracelets,

necklaces and watches when working with a lead acid battery. It can produce a short circuit current high enough to weld a ring or the like to metal causing a severe burn.

PREPARING TO TEST :

- 1.** Be sure area around battery is well ventilated while battery is being tested.
- 2.** Clean battery terminals. Be careful to keep corrosion from coming in contact with eyes.
- 3.** Inspect the battery for cracked or broken case or cover. If battery is damaged, do not use tester.
- 4.** If the battery is not sealed maintenance free, add distilled water in each cell until battery acid reaches level specified by the manufacturer. This helps purge excessive gas from cells. Do not overfill.
- 5.** If necessary to remove battery from vehicle to test, always remove ground terminal from battery first. Make sure all accessories in the vehicle are off to ensure you do not cause any arcing.

OPERATION & USE :

BATTERY TEST - BT301/BT501

- 1.** Before you test a battery in a vehicle, turn off the ignition, all accessories and loads. Close all the vehicle doors and the trunk lid.
- 2.** Make sure you have put 4pcs 1.5V batteries into the battery chamber. Oxryde batteries are not recommended because of the initial 1.7 Volt output. If the 1.5V battery runs out of power, screen will show "REPLACE INTERNAL BATTERY" or" POWER LOW". Replace those 4pcs 1.5V batteries before starting the test.

Note that nothing will be seen on the display until the tester is connected to a vehicle battery.

3. Make sure the battery terminals are clean. Wire brush them if necessary. Clamp the black load lead to the vehicle negative battery terminal. Clamp the red load lead to the vehicle positive battery terminal. Please clamp on the lead part of the terminal only. Clamping on the iron part of the terminal will lead to wrong test results.
4. Paper load: Open the clear cover. Insert paper to the paper feeding for auto running the paper into printer.

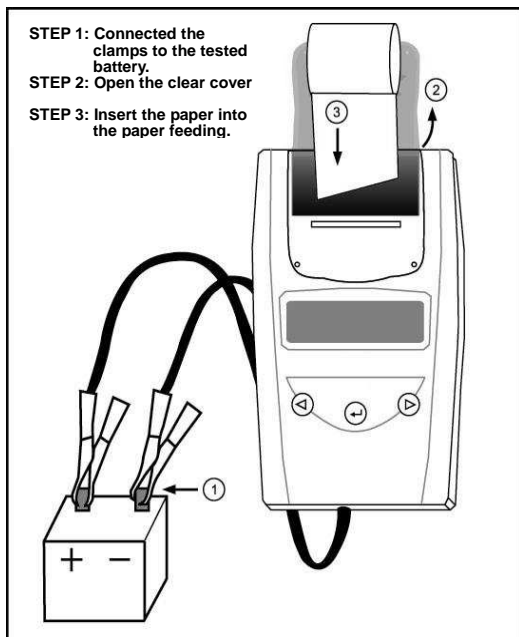

HOW TO REPLACE THE PAPER JAM

- STEP 1: Open the clear cover
STEP 2: Pull the paper slowly and straightly from the paper roll in the chamber

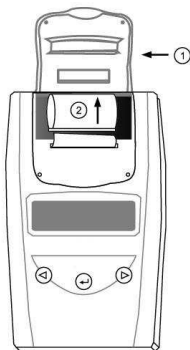

5. You will view the following screens :

*BT301

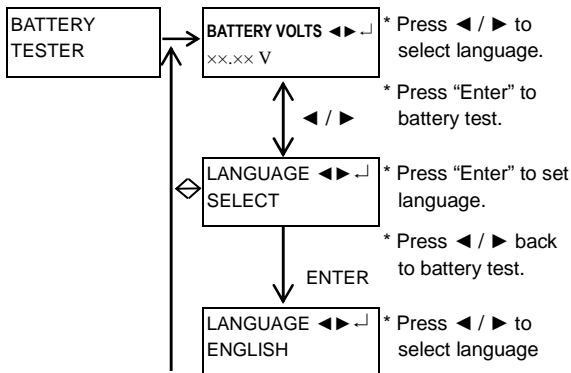

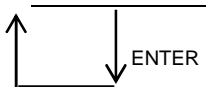

(English, French,
German, Spanish,
Italian, Portuguese,
Japanese)

* Press "Enter" to
confirm choice &
go back to battery
test.

***BT501**

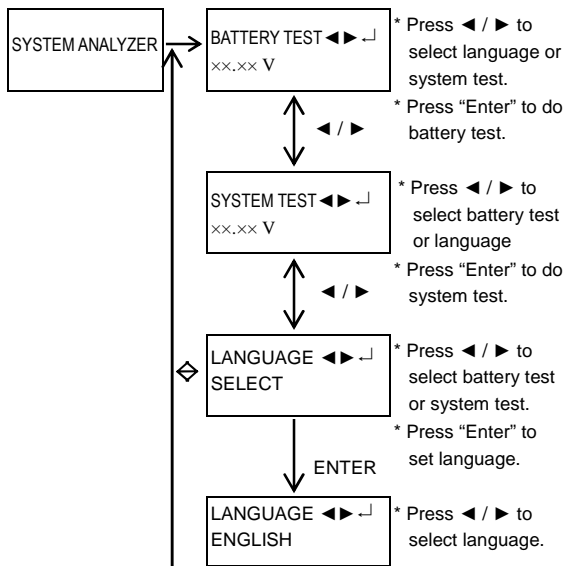

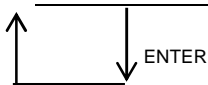

(English, French,
German, Spanish,
Italian, Portuguese,
Japanese.)

* Press "Enter" to
confirm choice &
go back to battery
test.

6. Press the ◀ ▶ key to select battery test. Press
«ENTER» button.

Example :

7. Press the ◀ ▶ key to select
the battery type :

BATTERY TYPE ◀ ▶ ↵
AGM FLAT PLATE

- a. REGULAR LIQUID
- b. AGM FLAT PLATE
- c. AGM SPIRAL
- d. VRLA/GEL

Press «ENTER» to confirm choice.

8. Press the ◀ ▶ key to select
the battery rating : SAE, EN,
IEC, DIN or JIS

SELECT RATING ◀ ▶ ↵
SAE

Press «ENTER» to confirm choice.

9. Press the ◀ ▶ key to input
the battery capacity of CCA :

SET CAPACITY ◀ ▶ ↵
xxxxx SAE

- SAE : 40~2000
- EN : 40~2100
- IEC : 30~1500 • DIN : 25~1300

• JIS : By Battery Type No.

Press «ENTER» to begin the test.

10. Test the battery for few
seconds.

TESTING

11. Press the ◀ ▶ key to select battery fully charged or not if tester asks. Press «ENTER» to confirm choice.

IS BATTERY ◀▶ ↵
CHARGED? YES

12. When the test is completed, the display shows the actual volts and the actual CCA or %. {Press the ◀ ▶ key to select: SOH (STATE OF HEALTH) or SOC (STATE OF CHARGE)}.

One of six results will be displayed:

GOOD & PASS :

The battery is good & capable of holding a charge.

GOOD & PASS
xx.xxV xxxx SAE

GOOD & RECHARGE :

The battery is good but needs to be recharged.

GOOD & RECHARGE
xx.xxV xxxx SAE

RECHARGE & RETEST :

Battery is discharged, the battery condition cannot be determined until it is fully charged. Recharge & retest the battery.

RECHARGE & RETEST
xx.xxV xxxx SAE

BAD & REPLACE :

The battery will not hold a charge. It should be replaced immediately.

BAD & REPLACE
xx.xxV xxxx SAE

BAD CELL & REPLACE :

The battery has at least one cell short circuit. It should be replaced immediately.

BAD CELL & REPLACE
xx.xxV xxxx SAE

LOAD ERROR :

The tested battery is bigger than 2000CCA or 200AH. Or the clamps are not connected properly. Please fully

LOAD ERROR

charge the battery and retest after excluding both previous reasons. If reading is the same, the battery should be replaced immediately.

WAITING FOR STABILIZATION:

For unstable batteries, with enough electrical activity potentially affecting the test results (weak battery and/or recently used batteries), please wait a few minutes for the battery to re-stabilise. Alternatively fully charge the battery then retest.

WAITING FOR
STABILIZATION

- 13.** Press the ◀ ▶ key to select result printing: YES or NO. Press «ENTER» to confirm your choice.

PRINT RESULT? ◀ ▶ ↵
NO

⊗ 24V System Test Printing:

The printer will not function for 24 Volt batteries system test printing. The 24V system test result will be recorded till you hook up to a 12V battery and the right screen shows up. Please select “YES” and press enter key to print the result and then disconnect the clamps. The screen will appear again after you reconnect the clamps. Please select “NO” and press the enter key to go back to the main menu.

PRINT 24V SYSTEM
RESULT? YES

- 14.** NO: Press «ENTER» return to step 5 or remove the test clamps from the battery posts after completion of testing batteries to end test.

SYSTEM TEST - BT501

1. Press «ENTER» button, you will view the following screen:

Example :

SYSTEM TEST
xx.xxV

2. Turn off all vehicle accessory loads such as light, air conditioning, radio, etc. before starting the engine.

TURN OFF LOADS
START ENGINE

3. When the engine is started, one of the three results will be displayed along with the actual reading measured.

CRANKING VOLTS NORMAL

The system is showing normal draw. Press «ENTER» to perform the charging system test.

CRANKING VOLTS
xx.xxV NORMAL

CRANKING VOLTS LOW

The cranking voltage is below normal limits, troubleshoot the starter with manufacturers recommended procedure.

CRANKING VOLTS
xx.xxV LOW

CRANKING VOLTS NO DETECTED

The cranking voltage is not detected.

CRANKING VOLTS
NO DETECTED

4. If the cranking voltage is normal, press «ENTER» to begin charging system test.
5. Press the «ENTER» key, you will view the following screen.
6. Press the «ENTER» key, one of the three results will be displayed along with the actual reading measured.

PRESS ENTER FOR
CHARGING TEST

MAKE SURE ALL
LOADS ARE OFF

LOW CHARGING VOLTS WHEN TEST AT IDLE

The alternator is not providing sufficient current to the battery.

Check the belts to ensure the alternator is rotating with engine running. If the belts are slipping or broken, replace the belts and retest. Check the connections from the alternator to the battery. If the connection is loose or heavily corroded, clean or replace the cable and retest. If the belts and connections are in good condition, replace the alternator.

ALT. IDLE VOLTS

xx.xxV LOW

CHARGING SYSTEM NORMAL WHEN TEST AT IDLE

The system is showing normal output from the alternator. No problem is detected.

ALT. IDLE VOLTS

xx.xxV NORMAL

HIGH CHARGING VOLTS WHEN TEST AT IDLE

The voltage output from the alternator to the battery exceeds the normal limits of a

functioning regulator. Check to ensure there is no loose connection and the ground connection is normal. If there is no connection issue, replace the regulator. Since most alternators have the regulator built-in, this will require you to replace the alternator. The normal high limit of a typical automotive regulator is 14.7 volts +/- 0.05. Check manufacturer specifications for the correct limit, as it will vary by vehicle type and manufacturer.

ALT. IDLE VOLTS

xx.xxV HIGH

7. Following the charging system at idle, press «ENTER» for the charging system with accessory loads. Turn on the blower to high (heat), highbeam headlights, and rear defogger. Do not use cyclical loads such as air conditioning or windshield wipers.

TURN ON LOADS

AND PRESS ENTER

8. When testing older model diesel engines, the users need to run up the engine to 2500 rpm for 15 seconds. You will view the screen as follows:

RUN ENGINE UP TO
2500 RPM 15 SEC.

9. Press «ENTER» to look for the amount of ripple from the charging system to the battery. One of two testing results will be displayed along with the actual testing measured.

RIPPLE DETECTED NORMAL

Diodes function well in the alternator / stator.

RIPPLE DETECTED
xx.xxV NORMAL

Or

NO RIPPLE DETECT

EXCESS RIPPLE DETECTED

One or more diodes in the alternator are not functioning or there is stator damage.

Check to ensure the alternator mounting is sturdy and that the belts are in good shape and functioning properly. If the mounting and belts are good, replace the alternator.

RIPPLE DETECTED
xx.xxV HIGH

10. Press the «ENTER» key to continue the charging system with accessory loads. One of the three results will be displayed along with the actual testing measured.

CHARGING SYSTEM HIGH WHEN TEST WITH ACCESSORY LOADS

The voltage output from the alternator to the battery

exceeds the normal limits of a functioning regulator.

Check to ensure there are no loose connections and that the ground connection is normal. If there are no

ALT. LOAD VOLTS
xx.xxV HIGH

connection issues, replace the regulator. Since most alternators have the regulator built-in, this will require you to replace the alternator.

CHARGING SYSTEM LOW WHEN TEST WITH ACCESSORY LOADS

The alternator is not providing sufficient current for the system's electrical loads and the charging current for the battery. Check the belts to ensure the alternator is rotating with the engine running. If the belts are slipping or broken, replace the belts and retest. Check the connections from the alternator to the battery. If the connection is loose or heavily corroded, clean or replace the cable and retest. If the belts and connections are in good working condition, replace the alternator.

ALT. LOAD VOLTS
xx.xxV LOW

CHARGING SYSTEM NORMAL WHEN TEST WITH ACCESSORY LOADS

The system is showing normal output from the alternator. No problem detected.

ALT. LOAD VOLTS
xx.xxV NORMAL

- 11.** Press «ENTER» when charging system test is completed finish. Turn all accessory loads and engine off. Press «ENTER» to return to step 1 or remove the test clamps from the battery posts after completion of testing to end test.

TEST OVER. TURN
OFF LOADS & ENGINE

- 12.** Press the ◀ ▶ key to select result printing: YES or NO. Press «ENTER» to confirm your choice.

PRINT RESULT? ◀ ▶ ↵
NO

GLOSSARY

What is a GEL battery?

A gel battery is a lead-acid electric storage battery that:
is sealed using special pressure valves and should never be opened.
is completely maintenance-free.*
uses a xixotropic gelled electrolyte.
uses a recombination reaction to prevent the escape of hydrogen and oxygen gases normally lost in a flooded lead-acid battery (particularly in deep cycle applications).
is non-spillable, and therefore can be operated in virtually any position.
However, upside-down installation is not recommend-ed.
Connections must be retorqued and the batteries should be cleaned periodically.

What is an AGM battery?

An AGM battery is a lead-acid electric storage battery that:
is sealed using special pressure valves and should never be opened.
is completely maintenance-free.*
has all of its electrolyte absorbed in separators consisting of a sponge-like mass of matted glass fibers.
uses a recombination reaction to prevent the escape of hydrogen and oxygen gases normally lost in a flooded lead-acid battery (particularly in deep cycle applications).
is non-spillable, and therefore can be operated in virtually any position.
However, upside-down installation is not recommended.
Connections must be retorqued and the batteries should be cleaned periodically.

What is a VRLA battery?

Valve Regulated Lead Acid Battery – This type of battery is sealed Maintenance Free with a “Bunce” Valve or Valves in the top of them that opens when a preset pressure is realized inside the battery and let’s the excess gas pressure out. Then the valve resets itself.

What is a SLI battery?

These initials stand for Starting, Lighting and Ignition, which are the three basic functions which a battery has to perform on all normal vehicles. Batteries given this description will have been specifically designed for service on cars and trucks within a voltage controlled electrical system. Those SLI batteries which are intended for heavy haulage vehicles fitted with large diesel motors may often be called COMMERCIAL batteries. They have to be much more powerful and more robust than batteries intended for cars.

What is STATE OF HEALTH?

It means how much battery capacity is left (%) comparing with the marked original battery capacity.

What is STATE OF CHARGE?

It means how many percent of the battery is actually charged.

What is CCA (COLD CRANKING AMPS)?

The current in amperes which a new fully charged battery can deliver for 30 seconds continuously without the terminal voltage falling below 1.2volts per cell, after it has been cooled to 0°F and held at that temperature. This rating reflects the ability of the battery to deliver engine starting currents under winter conditions.

What is AMPERE-HOUR?

The unit of measurement of electrical capacity. A current of one ampere for one hour implies the delivery or receipt of one ampere-hour of electricity. Current multiplied by time in hours equals ampere-hours.

TERMS AND CONDITIONS OF WARRANTY

Any battery tester defective in material or workmanship will be repaired or replaced according to published defective return test repair procedures. The existence of a defect shall be determined by the seller in accordance with published procedures. The published test procedures are available upon request.

This warranty does not cover any unit that has been damaged due to accident, abuse, alternation, use for a purpose other than that for which it was intended, or failure to follow operating instructions. This warranty is expressly limited to original retail buyers. This warranty is not assignable or transferable. Proof of purchase is required for all alleged claims. Warranty cannot be authorized without proof of purchase. Warranty claims must be sent pre-paid with dated proof of purchase. Damage incurred during shipment is the responsibility of the shipper (customer returning unit) If the returned unit qualifies for warranty, the shipper will only incur shipping cost. The seller reserves the right to substitute or offer alternative warranty options at its discretion.

The sole and exclusive remedy for any unit found to be defective is repair or replacement, at the option of the seller. In no event shall the seller be liable for any direct, indirect, special, incidental, or consequential damages (including lost profit) whether based on warranty, contract, tort, or any other legal theory.

RETURN GOODS:

Pack with sufficient over-pack to prevent damage during shipment. Damage incurred during return shipment is not covered under this warranty. Repair costs for such damages will be charged back to shipper.

REMARK:

WHEN RETURNING GOODS, PLEASE SHOW "RETURN GOODS" ON ALL INVOICES & RELATED SHIPPING DOCUMENTS TO PREVENT ANY EXTRA CHARGE."

